

TECHNICAL FEATURES

Code	Type of LED	Power P(W)	Input voltage (V)	Color temperature of LED (K)	Working ambient temperature (°C)	Dimensions ØxL (mm)	Weight (kg)	Energy efficiency class
TL01WW/NW SWH/SBK/SGD	SMD 2835	1x7W	220-240V AC	3000K / 4000K	-20 ÷ +40 °C	60x125 mm	0,40	E/E
SX04WW/NW SWH/SBK/SGD	SMD 2835	1x7W	220-240V AC	3000K / 4000K	-20 ÷ +40 °C	95x40 mm	0,30	E/D

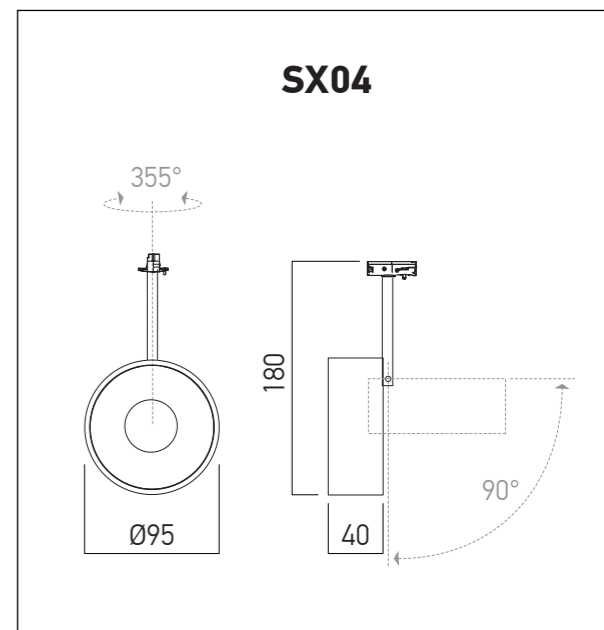
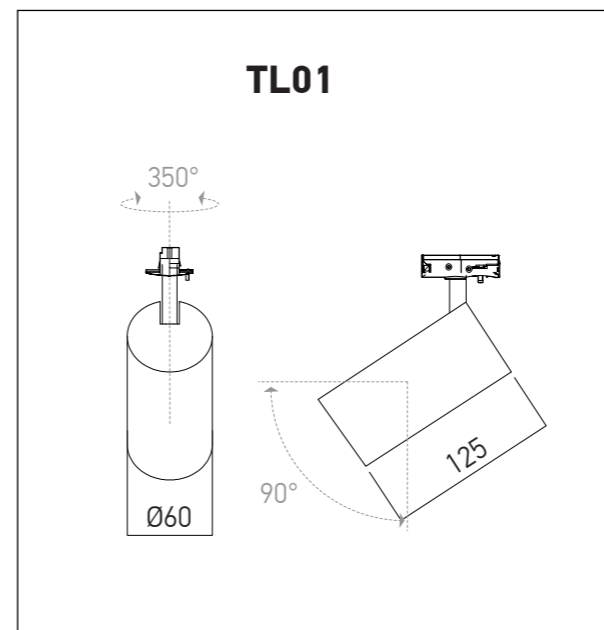
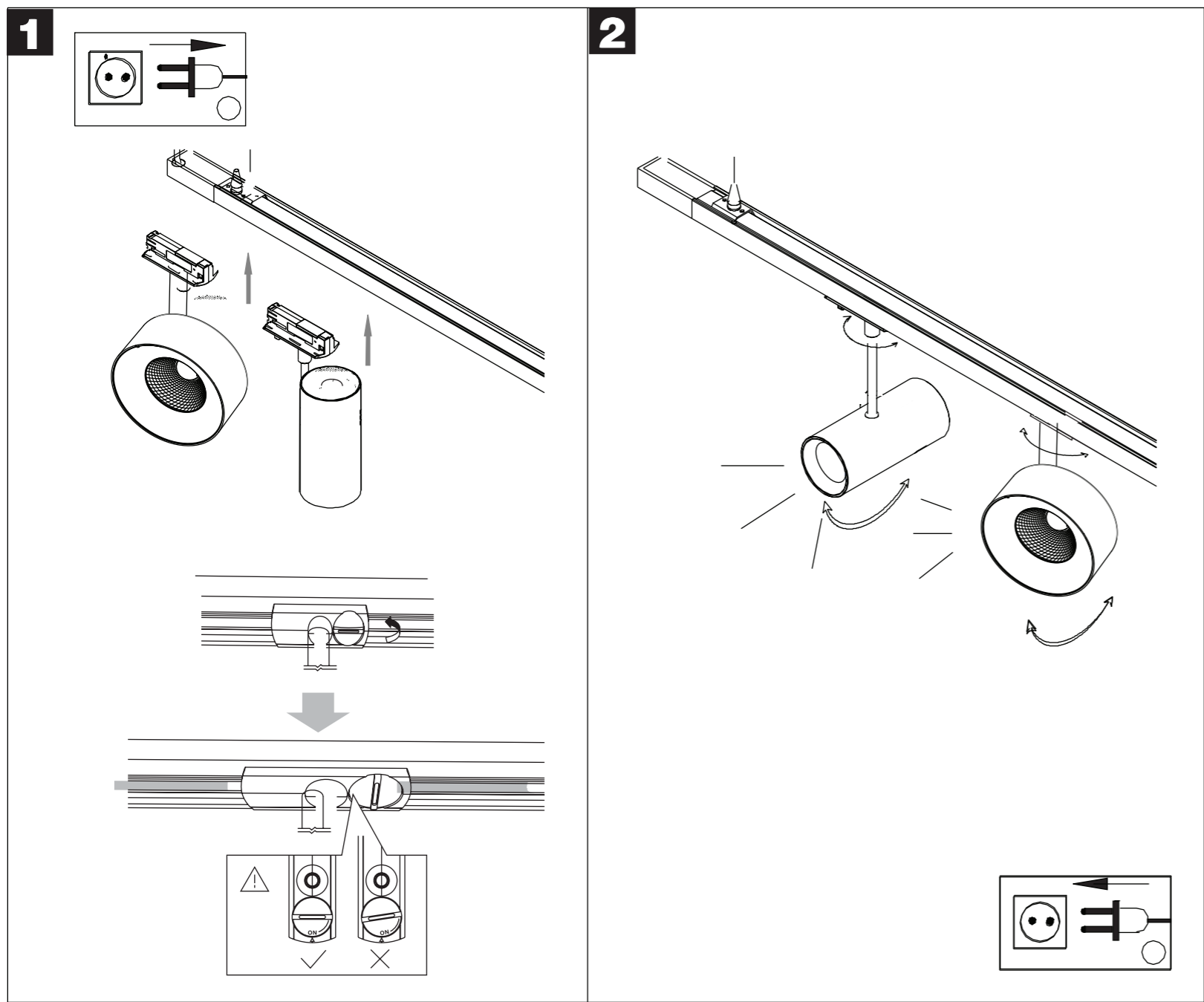

OPEN SIZE 420x297mm

CLOSED SIZE 105x148,5mm

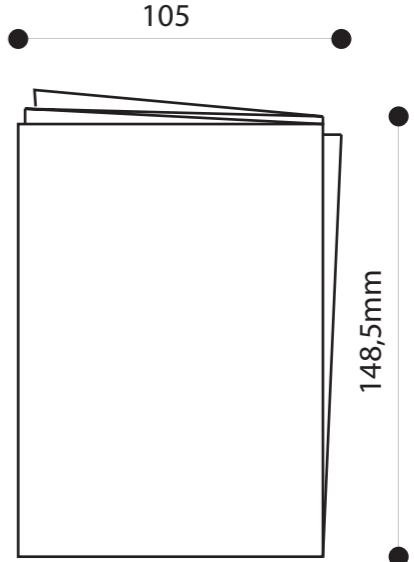
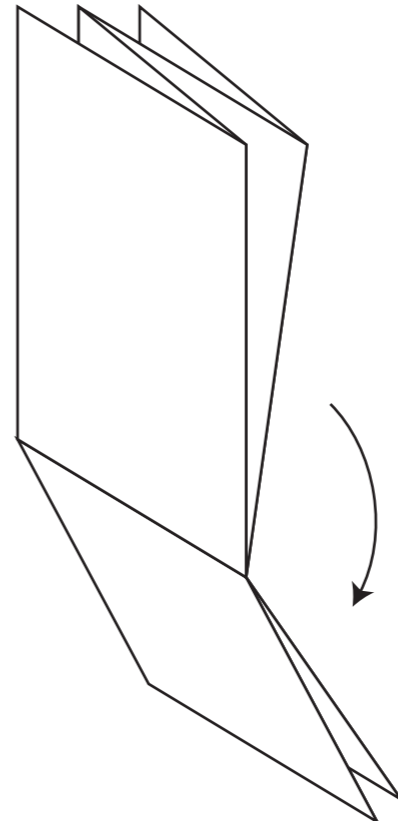
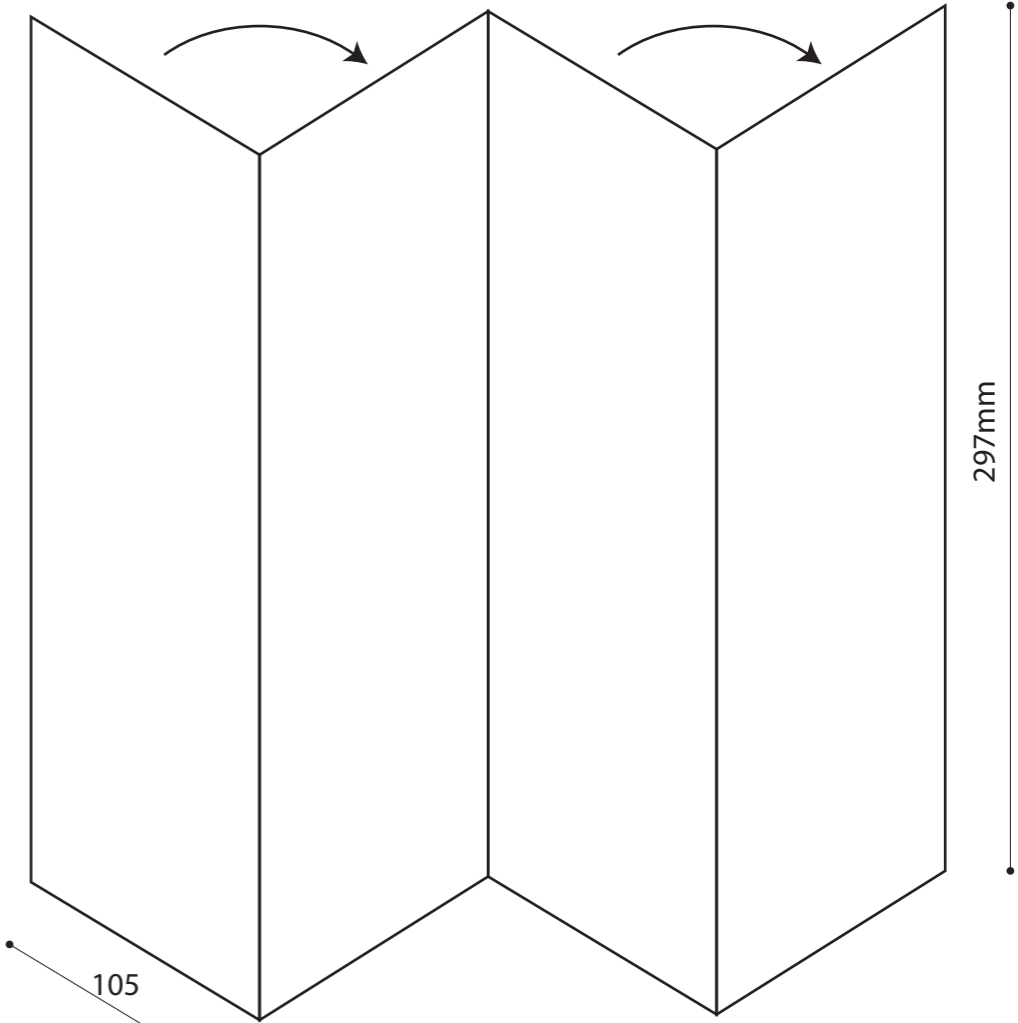
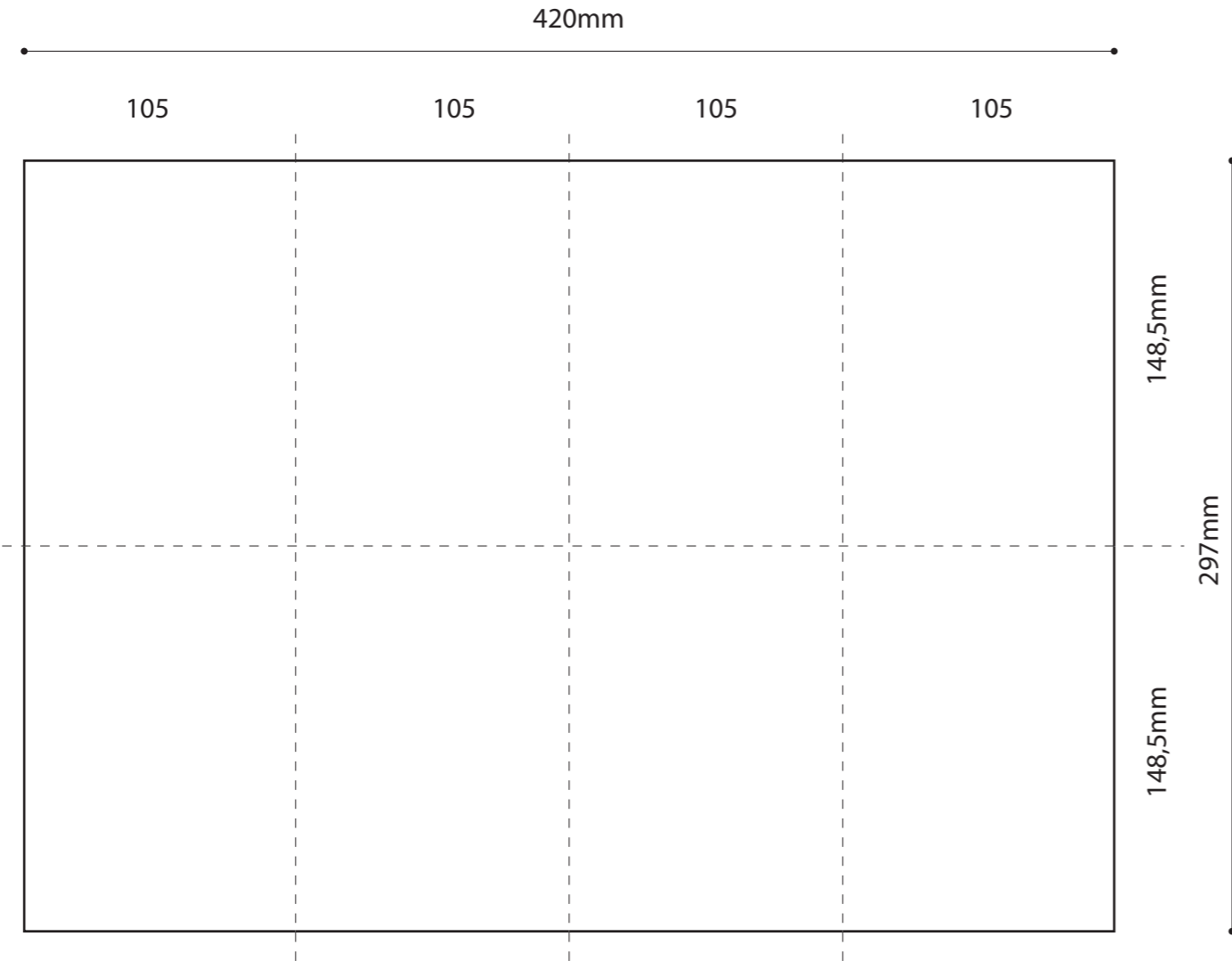

PRINT: 1 color (black) front and back side